

BMW Motorcycles Navigator

portable GPS with auto routing and voice

owner's manual and reference



© 2001 GARMIN Corporation

GARMIN International, Inc., 1200 E 151st Street, Olathe, Kansas 66062 U.S.A.
Tel. 913/397.8200 or 800/800.1020 Fax. 913/397.8282

GARMIN (Europe) Ltd., Unit 5, The Quadrangle, Abbey Park Industrial Estate, Romsey, SO51 9AQ U.K.
Tel. 44/1794.519944 Fax. 44/1794.519222

GARMIN Corp., No. 68, Jangshu 2nd Road, Shijr, Taipei County, Taiwan
Tel. 886/2.2642.9199 Fax. 886/2.2642.9099

All rights reserved. Except as expressly provided herein, no part of this manual may be reproduced, copied, transmitted, disseminated, downloaded or stored in any storage medium, for any purpose without prior written consent of GARMIN Corporation. GARMIN Corporation hereby grants permission to download a single copy of this manual onto a hard drive or other electronic storage medium to be viewed for personal use, provided that such electronic or printed copy of this manual contains the complete text of this copyright notice and provided further that any unauthorized commercial distribution of this manual is strictly prohibited.

Information in this manual is subject to change without notice. GARMIN Corporation reserves the right to change or improve its products and to make changes in the content without obligation to notify any person or organization of such changes. Visit the GARMIN web site for downloadable upgrades to the operating software and the Owner's Manual. The web site also contains information concerning the use and operation of other GARMIN products.

Web site address: www.garmin.com

GARMIN[®], AutoLocate[®], MapSource[®] and TracBack[®] are registered trademarks of GARMIN Corporation and may not be used without the express permission of GARMIN Corporation.

BMW[®] and the BMW logo are registered trademarks of BMW AG.

August 2001

Part Number 190-00206-10 Rev. B

Printed in Taiwan

Welcome

Thank you for choosing the BMW Motorcycles Navigator. The Navigator offers true turn-by-turn navigation with its auto-routing feature. At the touch of a button, you now have access to the shortest and fastest routes, turn directions, and estimated time of arrival at your intended destination. Along the way, the Navigator provides automated voice prompts, alerting you to necessary turns, distance to upcoming turns, route deviation, and distance to the final destination.

The Navigator is compact and portable. This fairing-mounted unit is operated from your vehicle's battery using the included wiring harness, or by six AA batteries. Voice commands are clearly heard through the vehicle's audio system speakers. The Navigator can easily be viewed in any lighting condition, with its 4-inch, high resolution, 16-color display. The unit's built-in basemap provides detail for interstates, interstate exit data, highways, rivers and lakes in the United States, Canada and Mexico (no exit data for Mexico), plus commonly used streets in metropolitan areas. With the press of a button, the built-in basemap will provide turn-by-turn guidance to a destination via interstates and highways. With downloaded maps from the MapSource City Navigator CD-ROM, Navigator provides turn-by-turn guidance down to residential street-level detail.

About This Manual

Make sure you take the time to read the Quick Start Guide first to get acquainted with all of the basic features of the Navigator. After you have read the Quick Start Guide, you can read through this owner's manual in order to understand the operating features of the Navigator in detail. This manual is organized into three sections for your convenience. The **Introduction Section** provides FCC and safety information and the table of contents. The **Reference Section** provides details about all of the features of the Navigator, organized by topic. The **Appendices** contain information on items such as accessories, specifications, and an index organized by subject.

Introduction

Welcome



The Navigator uses GPS technology in order to find your precise location. GPS stands for Global Positioning System, a group of 24 satellites, circling the earth twice a day, at an altitude of about 12,000 miles. The satellites transmit very low power radio signals containing position and time information, allowing anyone with a GPS receiver to determine their location on the earth within 100 meters or better. For more detailed information regarding GPS, we have prepared a booklet called "GPS Guide for Beginners" which is available to you from our web site at www.garmin.com.

Introduction

Table of Contents

Introduction	1	Marking Waypoints	26
Welcome	1	Using the Find Menu	27
About This Manual	1	Finding Items by Name or by Nearest	27
Table Of Contents	2	Finding a Waypoint	28
Safety Warnings and Cautions	4	Finding a City	28
Software License Agreement	6	Finding an Exit	29
FCC Compliance	7	Finding a Point of Interest	30
Limited Warranty	8	Finding an Address or Intersection	31
Unit Description	9	Recently Found Places	32
Keys	10	Using the Routes Menu	32
Features/Data Entry	11	GPS Information Page	35
Unit Pages at a Glance	12	Sky View and Signal Strength Bars	35
Reference Section	13	Receiver Status	36
The Map Page	13	Accuracy	37
Map Page Nav Info	14	GPS Info Page Options	38
Zooming, Panning, and Pointing	15	Map Source Information	39
Routing to a Map Feature or Location	17	System Info	39
Map Page Options	18		
Next Turn Page	21		
Current Route Page	22		
Trip Information Page	24		

System Setup	40
System Setup Pages	40
General Tab	41
Guidance Tab	42
Routing Tab	43
Time Tab	45
Safety Tab	46
Track Log Tab	46
Language Tab	47
Interface Tab	48
Appendices50
Appendix A: Optional Accessories	50
Appendix B: Wiring and Interfacing	52
Appendix C: Maintenance	53
Appendix D: Messages	54
Appendix E: Specifications	56
Appendix F: Time Offset	58
Appendix G: Index	59

Introduction

Table of Contents

Introduction

Warnings and Cautions

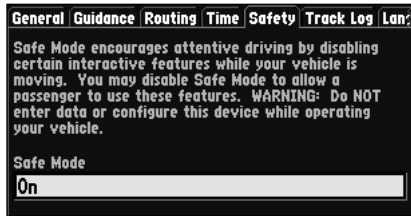

Your Navigator is equipped with a 'Safe Mode' feature to improve rider safety. By default, this feature is enabled. For automotive use, Safe Mode can be turned off to allow a passenger to operate the unit.

When your vehicle is moving, Safe Mode disables certain Navigator functions which require significant operator attention and may become a distraction to use while riding or driving. See page 46 for details.

Safety Warnings and Cautions—Read This First!

WARNING: For use in vehicles, it is the sole responsibility of the owner/operator of the Navigator to place and secure the Navigator so that it will not interfere with the vehicle operating controls and safety devices, obstruct the operator's view of driving conditions, or cause damage or personal injury in the event of an accident. Do not mount the Navigator over airbag panels or in the field of airbag deployment. Airbags expand with a rapid force that can propel objects in their path towards the vehicle driver or passengers causing possible injury. Refer to airbag safety precautions contained in the vehicle owner's manual. Do not mount the Navigator in a place where the driver or passengers are likely to impact it in an accident or collision. The mounting hardware provided by GARMIN is not warranted against collision damage or the consequences thereof.

WARNING: When used in vehicles, it is the sole responsibility of the driver of the vehicle to operate the vehicle in a safe manner, maintain full surveillance of all driving conditions at all times, and not become distracted by the Navigator to the exclusion of safe driving practices. It is unsafe to operate the controls of the Navigator while you are riding or driving. Failure by the driver of a vehicle equipped with a Navigator to pay full attention to operation of the vehicle and road conditions while the vehicle is in motion could result in an accident or collision with property damage and personal injury.

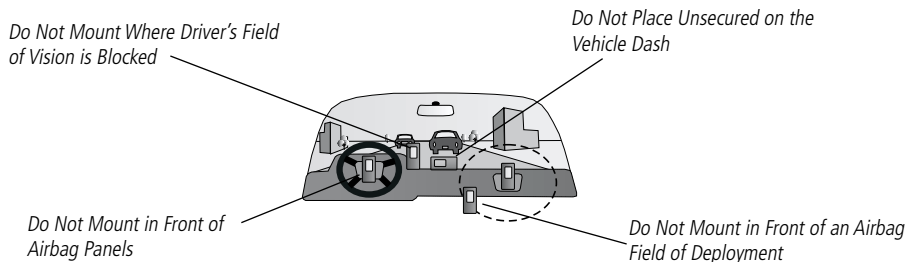

CAUTION: The Global Positioning System (GPS) is operated by the government of the United States, which is solely responsible for its accuracy and maintenance. The system is subject to changes that could affect the accuracy and performance of all GPS equipment. Although the Navigator is a precision NAVigation AID (NAVAID), any NAVAID can be misused or misinterpreted and, therefore, become unsafe.

MAP DATA INFORMATION: One of the goals of GARMIN is to provide customers with the most complete and accurate cartography that is available to us at a reasonable cost. We use a combination of governmental and private data sources, which we identify as required in product literature and copyright messages displayed to the consumer. Virtually all data sources contain inaccurate or incomplete data to some degree. This is particularly true outside the United States, where complete and accurate digital data is either not available or prohibitively expensive.

CAUTION: IT IS THE USER'S RESPONSIBILITY TO USE THIS PRODUCT PRUDENTLY. THIS PRODUCT IS INTENDED TO BE USED ONLY AS A TRAVEL AID AND MUST NOT BE USED FOR ANY PURPOSE REQUIRING PRECISE MEASUREMENT OF DIRECTION, DISTANCE, LOCATION, OR TOPOGRAPHY. THIS PRODUCT SHOULD NOT BE USED TO DETERMINE GROUND PROXIMITY FOR AIRCRAFT NAVIGATION.

Introduction

Map Data



Because the map data may not be perfect, it will help at times to cross-check the unit's map with your actual surroundings to confirm that you are arriving at the exact destination.

Introduction

Software License Agreement

Software License Agreement

BY USING THE NAVIGATOR, YOU AGREE TO BE BOUND BY THE TERMS AND CONDITIONS OF THE FOLLOWING SOFTWARE LICENSE AGREEMENT. PLEASE READ THIS AGREEMENT CAREFULLY.

GARMIN Corporation (“GARMIN”) grants you a limited license to use the software embedded in this device (the “Software”) in binary executable form in the normal operation of the product. Title, ownership rights and intellectual property rights in and to the Software remain in GARMIN.

You acknowledge that the Software is the property of GARMIN and is protected under the United States of America copyright laws and international copyright treaties. You further acknowledge that the structure, organization and code of the Software are valuable trade secrets of GARMIN and that the Software in source code form remains a valuable trade secret of GARMIN. You agree not to decompile, disassemble, modify, reverse assemble, reverse engineer or reduce to human readable form the Software or any part thereof or create any derivative works based on the Software. You agree not to export or re-export the Software to any country in violation of the export control laws of the United States of America.

FCC Compliance

The BMW Motorcycles Navigator complies with Part 15 of the FCC interference limits for Class B digital devices FOR HOME OR OFFICE USE (“home or office” interference requirements are more stringent than “outdoor” requirements). Operation of this device is subject to the following conditions: (1) This device may not cause harmful interference, and (2) this device must accept any interference received, including interference that may cause undesired operation.

This equipment has been tested and found to comply with the limits for a Class B digital device, pursuant to part 15 of the FCC Rules. These limits are designed to provide reasonable protection against harmful interference in a residential installation. This equipment generates, uses, and can radiate radio frequency (RF) energy and, if not installed and used in accordance with instructions, may cause harmful interference to radio communications. However, there is no guarantee that interference will not occur in a particular installation. If this device does cause harmful interference to radio or television reception, which can be determined by turning this device off and on, the user is encouraged to try and correct the interference by one or more of the following measures:

- Reorient or relocate the receiving antenna.
- Increase the separation between the equipment and receiver.
- Connect the equipment into an outlet on a circuit different from that to which the receiver is connected.
- Consult the dealer or an experienced radio/TV technician for help.

Introduction

FCC Compliance

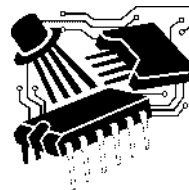

The Navigator does not contain any user-serviceable parts. Repairs should only be made by an authorized GARMIN service center. Unauthorized repairs or modifications could result in permanent damage to the equipment, and void your warranty and your authority to operate this device under Part 15 regulations.

Limited Warranty

Limited Warranty

GARMIN Corporation warrants this product to be free from defects in materials and manufacture for one year from the date of purchase. GARMIN will, at its sole option, repair or replace any components that fail in normal use. Such repairs or replacement will be made at no charge to the customer for parts or labor. The customer is, however, responsible for any transportation costs. This warranty does not cover failures due to abuse, misuse, accident or unauthorized alteration or repairs.

THE WARRANTIES AND REMEDIES CONTAINED HEREIN ARE EXCLUSIVE AND IN LIEU OF ALL OTHER WARRANTIES EXPRESS OR IMPLIED OR STATUTORY, INCLUDING ANY LIABILITY ARISING UNDER ANY WARRANTY OF MERCHANTABILITY OR FITNESS FOR A PARTICULAR PURPOSE, STATUTORY OR OTHERWISE. THIS WARRANTY GIVES YOU SPECIFIC LEGAL RIGHTS, WHICH MAY VARY FROM STATE TO STATE.

IN NO EVENT SHALL GARMIN BE LIABLE FOR ANY INCIDENTAL, SPECIAL, INDIRECT OR CONSEQUENTIAL DAMAGES, WHETHER RESULTING FROM THE USE, MISUSE, OR INABILITY TO USE THIS PRODUCT OR FROM DEFECTS IN THE PRODUCT. SOME STATES DO NOT ALLOW THE EXCLUSION OF INCIDENTAL OR CONSEQUENTIAL DAMAGES, SO THE ABOVE LIMITATIONS MAY NOT APPLY TO YOU.

To obtain warranty service, contact your GARMIN dealer or call the GARMIN Customer Service department (913-397-8200) for a returned merchandise tracking number. The unit should be securely packaged with the tracking number clearly marked on the outside of the package and sent freight prepaid and insured to a GARMIN warranty service station. A copy of the original sales receipt is required as the proof of purchase for warranty repairs. GARMIN retains the exclusive right to repair or replace the unit or software or offer a full refund of the purchase price at its sole discretion. SUCH REMEDY SHALL BE YOUR SOLE AND EXCLUSIVE REMEDY FOR ANY BREACH OF WARRANTY.

Introduction

Keypad Usage



POWER (Red Bulb Symbol)- Press and hold to turn the Navigator on and off. Press momentarily while power is on to display the backlight/contrast adjustment window.

PAGE- Switches between main pages and returns display from an option window back to a main page.

QUIT- Returns display to a previous page. When entering data, restores the previous value (cancels data entry).

ENTER/MARK- Confirms a selected menu option. When entering data, it allows you to initiate entry, and then to accept the selected value(s). Press and hold to capture your present position and save it as a waypoint. **ENTER/MARK** can also capture the location of the panning arrow on the Map Page.

ROCKER KEYPAD- Selects menu options and enters data. Also controls movement of the panning cursor on the Map Page.

Zoom IN and OUT- Adjusts map scale to show a smaller area (more detail) or a larger area (less detail).

FIND- Searches the database for Cities, Interstate Exits, Waypoints, BMW Dealers and Recently found places. If an optional MapSource City Navigator or MetroGuide map data card is installed, it also searches for Points of Interest, Addresses, or Intersections. Allows the listed items to be viewed on a map or selected as a destination (Note: MetroGuide will not provide turn-by-turn navigation or voice commands).

MENU- Displays a menu of options for the current page. Press twice to display System Setup options.

ROUTE- Displays a pop-up window of route navigation features.

VOL/SPEAK- Adjusts the speaker volume. Press and hold until the controller appears on the left side of the screen. To hear the volume count (i.e. 1, 2, 3, 4, 5, 6, 7, 8) press up or down on the rocker keypad. Each press will activate the audio number. Pressing **VOL/SPEAK** also triggers the voice repeat function when navigating. Voice repeat will repeat the instructions in the last voice prompt.

Features/Data Entry

The following features and data entry procedures are referred to throughout this manual.

CURSOR- A highlighted area on the screen which can be moved up/down/left/right with the **ROCKER KEYPAD** to select individual fields on the display. Moving the cursor to a given location allows you to begin data entry or scroll through a list.

FIELD- The location on a page where a group of characters or an option is entered and displayed. The cursor is placed on a field (using the **ROCKER KEYPAD**) to begin data entry or selection of options.

To enter data in a data field:

1. Use the **ROCKER KEYPAD** to highlight the desired data field. Press **ENTER** to begin data entry.
2. Use the **ROCKER KEYPAD** to enter the desired data. **UP/DOWN** to select the desired character and **RIGHT** to move to the next character field. **LEFT** allows you to back up to the previous character field or, when at the left most character field, to clear the entire data field.
3. Once the desired data has been entered, press **ENTER** to confirm.

ON-SCREEN BUTTON- Similar to “Field”. Place the cursor on a button and press **ENTER** to select the action corresponding to that button. An example of an on-screen button is the ‘Route to It’ button appearing at the bottom of the Waypoint Marked Page.

SCROLL BAR- When viewing a list of items too long to display on a single page, a scroll bar will appear along the right-hand side of the list. The position of the scroll bar indicates which portion of the list is currently being displayed. The height of the scroll bar indicates the number of items in the list. To scroll through a list of items, use the **UP/DOWN** portion of the **ROCKER KEYPAD**.

DEFAULT- A system-selected format, built into the operating software or the unit’s memory, that will be followed unless the user chooses a different setting. For example, the default setting for speed readings is ‘miles per hour’ but can be changed to ‘kilometers per hour’. Once a setting is changed, the new setting is retained until another change is made or a ‘Restore Original Settings’ menu option is selected.

Introduction

Features/Data Entry



An example of a “button”—the ‘Route to It’ button on the Waypoint Marked Page.



When viewing a list of items too long to display on a single page, a scroll bar will appear along the right-hand side of the list. Also, using the Left/Right portion of the **ROCKER KEYPAD** will scroll information one full screen at a time.

Introduction

Unit Pages

Unit Pages at a Glance

All of the information needed to operate the Navigator is found on ‘pages’—or, display screens. There are three main pages, the Map, Trip Information, and Current Route. The Current Route Page is only available during navigation (i.e., when a destination is selected). A fourth screen, the Next Turn Page, is also available during navigation. Press the **PAGE** or **QUIT** key to switch back and forth between pages. The Reference Section describes in detail what each page does and how they are configured.

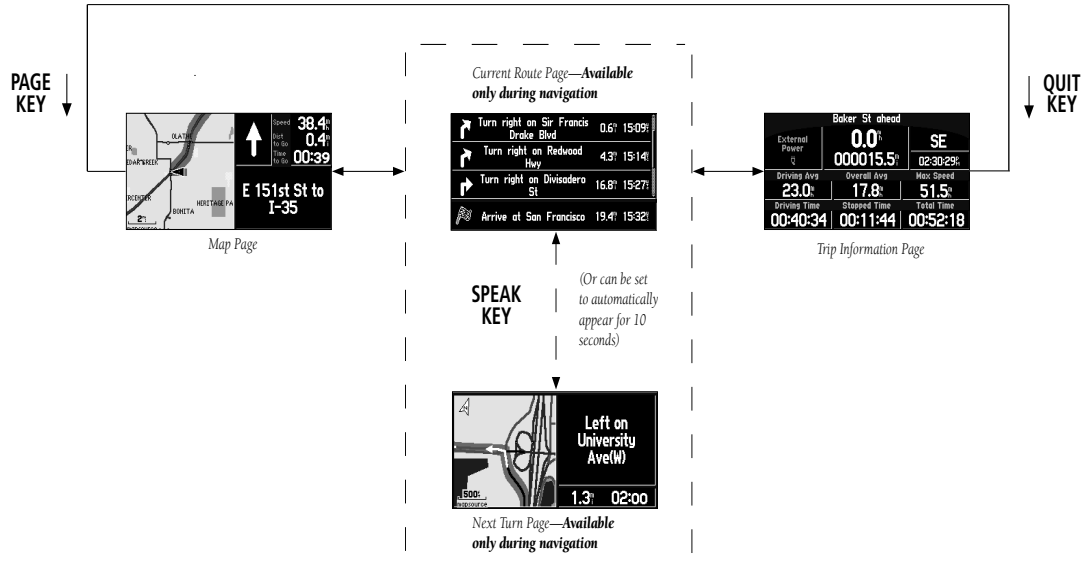

Reference

The Map Page

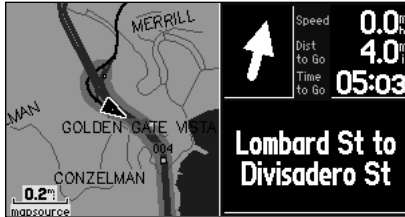

Clear driving instructions are displayed when you are navigating a route.

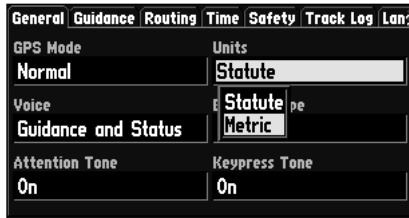

Your vehicle speed can be displayed in miles per hour or kilometers per hour.

When you are not riding on roads that are present in the maps, you may see a circle drawn around the position pointer. This is an 'accuracy circle'. The Navigator uses both map resolution and GPS accuracy in defining your location to a point within this "accuracy circle". The smaller the circle, the more accurate your location. More detailed map features as well as information about those features can be displayed using a data card containing map data transferred from a GARMIN MapSource CD-ROM. When you zoom into smaller map areas, "MapSource" will appear directly below the map scale indicating that MapSource data is being used to draw a more detailed map.

Map Page Navigation Information

The following navigation information can be displayed on the Map Page:

Current Direction (N, S, E, or W) - Cardinal letters indicate the direction you are traveling when not navigating a route. This is not displayed when you are navigating.

Direction To Go (Arrow) - An arrow that points to the next turn in the route when moving on an active route.

Speed - Your rate of travel which can be displayed in miles per hour or kilometers per hour.

Distance To Go - When navigating a Route, the distance remaining to reach the next turn will be displayed. When not navigating a Route, this field is not displayed.

Time To Go - When navigating a Route, the time to go before reaching the next turn is displayed. When not navigating a Route, the time for the current time zone is displayed in either 12 or 24 hour format.

Driving Instructions - Given in text format only when you are navigating a route. When you are not navigating, the next intersection is displayed.

Zooming, Panning and Pointing

There are three main actions you can perform on the Map Page: zooming, panning, and pointing. The map display has 24 map scales (from 120 feet to 800 miles) which are selected by pressing the **IN** and **OUT** zoom keys. The current map scale is indicated in the bottom left corner of the map display.

To change the map scale:

1. Press the **IN** zoom key to see a smaller area with more detail.
2. Press the **OUT** zoom key to see a larger area with less detail.

When zoomed in to smaller map areas, 'overzoom' appears directly below the map scale. This indicates the current scale exceeds the optimum resolution of available map detail. Extra caution should be used in 'overzoom' since some detail, such as roads, are drawn using widely spaced points and the actual layout of these details may differ from the map presentation.

Panning allows you to move the map in order to view areas beyond the current map area. This provides a 'look ahead' capability which is particularly useful with smaller map areas. To pan, use the **ROCKER KEYPAD** to move the map in any direction, including diagonally. Once you are finished with panning, you can quickly remove the panning arrow and re-center the map on your present position by pressing the **QUIT** key.

As you begin to pan the map, a pointer appears. This map pointer will serve as a target marker for the map. If you change the scale, the map is redrawn with the pointer at the center. When the pointer is placed on an object, the name of that object will be highlighted. (If the name wasn't originally displayed, it will appear when the pointer is placed on the object.) This feature applies to everything displayed on the map except route lines and track log data. When a waypoint name is highlighted, you can review information about the waypoint, list waypoint options, or execute a 'Route to It' directly from the Map Page.

Reference

The Map Page

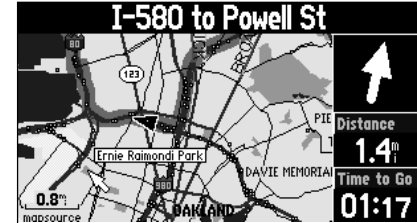

The Map Page showing the panning arrow and a highlighted map feature or point of interest.



The Information Page for the park highlighted in the screen above.

Reference

The Map Page



Once the 'Waypoint Created' Page appears, the waypoint is stored in memory.



The 'Waypoint Created' Page appears with a default three-digit number for its name which can be changed to something a little more meaningful (up to 10 characters in length).

To select an on-screen location with the panning pointer:

1. Use the **ROCKER KEYPAD** to highlight the desired item.
2. To view information for the selected item, press **ENTER**.
3. To exit the information pages, press **QUIT**.

The 'Route to It' function can be used anywhere on the map. If nothing currently exists at the map pointer position, a new waypoint will be created at the pointer's location before the 'Route to It' is started. You can also create a waypoint on the Map Page without selecting it as a 'Route to It' destination.

To create a new waypoint from the Map Page:

1. Use the **ROCKER KEYPAD** to point to the desired location on the map and press **ENTER** briefly. A 'Waypoint Created Page' will appear, with an auto-assigned name (3-digit number) for the waypoint.
2. You can delete the waypoint, show it on the map, or Route to It. Select the desired option and press **ENTER**.

Once you are finished with panning, you can quickly remove the panning arrow and re-center the map on your present position by pressing the **QUIT** key.

The Map Page

To mark your current location on the Map Page and save as a waypoint:

1. Press and hold the **ENTER** key for approximately two seconds. A 'Waypoint Marked' page will appear with a pre-assigned name, symbol, position and elevation for the new waypoint. When the 'Waypoint Marked Page' appears, the waypoint is marked.
2. The Navigator will automatically assign a three-digit number as the waypoint name, but you may select any name you want, up to ten characters in length. To change the name, highlight the identifier field, press **ENTER** and use the **ROCKER KEYPAD** to enter the desired waypoint name. Press **ENTER** once all characters for the waypoint name have been entered.
3. To select a different waypoint symbol, which will appear on the map, highlight the symbol field and press **ENTER**. A list of available symbols will appear. Use the **ROCKER KEYPAD** to select the desired symbol and press **ENTER**.
4. You can route to the waypoint, show it on the map page, or delete it. Use the **ROCKER KEYPAD** to select the option you desire and press **ENTER**.

Routing to a Map Feature or Location

1. Use the **ROCKER KEYPAD** to move the arrow to the desired feature or location on the map.
2. Press **ENTER** to display detailed information about the item.
3. To route to the location on the map, select 'Route to It' on the information page for that item and press **ENTER**. The **ROUTE** preference window appears. Select Faster Time, Shorter Distance, or Off Road, and press **ENTER**. The Navigator will route you to the selected destination using turn-by-turn navigation and voice prompting.



Once you have marked a waypoint, you can route to it, show it on the map, or delete it.



You can mark your current position from any page, not just the Map Page.

Reference

The Map Page



The Options Menu on the Map Page allows you to customize the Map Page.



You can adjust the size of the map by using the 'Select Layout' option.

Map Page Options

Like each of the main pages, the Map Page is menu-driven. With the Map Page displayed, pressing **MENU** will display an options menu, allowing you to customize the page to your preferences and/or select special features which specifically relate to the Map Page. To display the Map Page options menu, press **MENU** (with the Map Page displayed). The following options are available:

- Show Full Screen Map (or) Show Map and Nav Info
- Use Indoors (or) Use Outdoors
- Measure Distance
- Select Layout
- Map Setup

Show Full Screen Map (or) Show Map and Nav Info—'Show Full Screen Map' removes all screen information for the largest possible map display. 'Show Map and Nav Info' shows the map and the navigation information for the current layout.

Use Indoors (or) Use Outdoors—The 'Use Indoors' option stops satellite reception, conserves power usage, and speeds Map Page drawing. The 'Use Outdoors' option listens to satellites for real-time navigation.

Measure Distance— Allows you to measure the distance between any two points you choose on the Map Page. Also displays the latitude and longitude of the pointer.

Select Layout—Selects between Square Map and Wide Map. Square Map shows the map on one half of the display, navigation information on the other half. Navigation information includes direction to next turn, vehicle speed, distance to next turn, time to next turn, and driving instructions in text format. Wide map shows the map on three quarters of the screen, the remaining quarter displays navigation information (direction to next turn, vehicle speed, distance to next turn, time to next turn, and driving instructions in text format appearing at the top of the display).

Reference

To measure the distance between two points:

1. From the Map Page, press **MENU**.
2. Select 'Measure Distance' and press **ENTER**. An on-screen pointer will appear on the map display at your current location.
3. Move the panning arrow to the desired reference point, the point you want to measure from, and press **ENTER**.
4. Move the panning arrow to the second point, to which you want to measure. The direction and distance from the reference point is shown on the top of the Map Page.
5. Press the **QUIT** key or select 'Stop Measure Distance' on the menu to return to the regular Map Page display.

Map Setup—allows you to configure the map display to your preferences, including map detail, map orientation, automatic zooming, and color mode. The map setup options are organized under a series of 'file tabs', making individual selections easier to locate and change. The following table describes the file tabs and settings available under each tab:

Common Settings

Text—Specifies the text size that a map item will be displayed in. Selecting 'None' will turn off the text display for that item.

Zoom—Specifies the maximum map scale at which a map item will be displayed. If 'Auto' is selected, the maximum map scale will be determined by the 'Detail' setting to prevent map clutter. If 'Off' is selected, the item will not be shown.

The Map Page

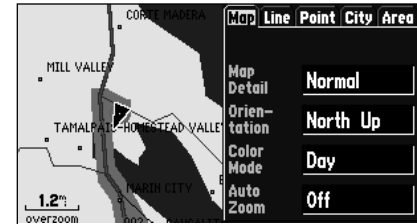

A series of tabs allow you to change the Map Page setup options.

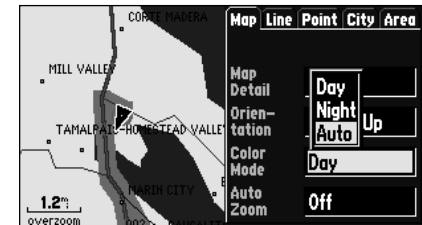

You can adjust the map colors for day or night operation for maximum clarity.

Reference

The Map Page

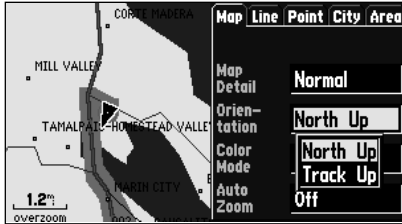

Selecting 'North Up' will display the map with North at the top. Selecting 'Track Up' will automatically rotate the map to keep your current direction of travel at the top of the screen.

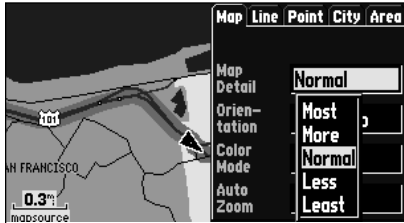

The 'Normal' setting for map detail is usually the best setting for typical operation.

Map Options

Map Detail - Adjusts the amount of map information, such as roads, that is displayed. 'Most' shows maximum detail and 'Least' shows minimum detail. The higher level of detail, the slower the map redrawing time.

Orientation - Selecting 'North Up' will display the map with North at the top. Selecting 'Track Up' will automatically rotate the map to keep your current direction of travel at the top of the screen. A 'North' indicator is displayed on the map when in the 'Track Up' mode.

Color Mode - Select between Day, Night, or Automatic for best viewing conditions.

AutoZoom - When 'On', this option will automatically adjust the map scale to show both your current location and the next item you are navigating to.

Line Options

Track Log - Controls the display of the 'Track Log' on the map.

Railroad - Controls the display of railroads on the map.

Street Label - Controls the display of street names on the map.

Other Options

Point - Controls the display of points of interest on the map.

City - Controls the display of cities on the map.

Area - Controls the display of rivers, lakes, parks, and other areas (airports, shopping malls, hospitals, etc.).

Next Turn Page

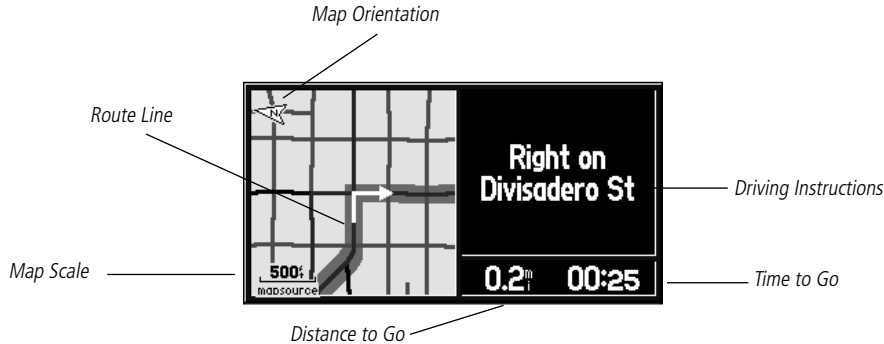

The Next Turn Page displays in detailed format the features of the next turn in the route. When a route is being navigated, the Next Turn Page appears for ten seconds prior to reaching a turn. The top-view map is oriented to the inbound direction for the turn. Map scale is adjustable using the **IN/OUT** zoom keys. The page shows the distance and time to the next turn, and driving directions in text format. To clear the Next Turn Page and return to the previous page at any time, press either the **QUIT** or **ENTER** key.

The Next Turn Page can be turned off completely, set to automatically appear when navigating a route, set to appear only when the **SPEAK** key is pressed, or both. See the System Setup on page 42 for instructions on configuring the Next Turn Page. When not navigating a route, the Next Turn Page is no longer available.

Reference

Next Turn Page



You can select when the Next Turn Page appears, or you can turn it off completely.

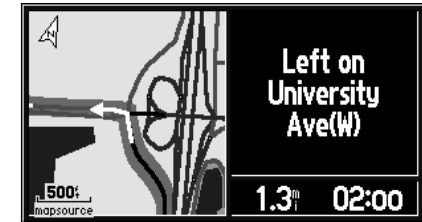

The Next Turn Page shows the distance and time to the next turn, along with driving instructions.

Reference

Current Route Page

↓	Make a U-turn	1.1 ^m	20:55 ^z
↗	Turn right on Redwood Hwy	4.9 ^m	21:04 ^z
↖	Turn right off of Redwood Hwy	7.9 ^m	21:07 ^z
↓	Turn right off of Hwy 131	8.6 ^m	21:08 ^z

You can change the displayed time to show arrival times or time to reach each turn.

Current Route Page

	Driving Instructions		Time to Go
↗	Turn right on Sir Francis Drake Blvd	0.6 ^m	15:09 ^z
↗	Turn right on Redwood Hwy	4.3 ^m	15:14 ^z
↗	Turn right on Divisadero St	16.8 ^m	15:27 ^z
🚩	Arrive at San Francisco	19.4 ^m	15:32 ^z
	Distance to Go		

Direction of Turn

Scroll Bar

When the Navigator is navigating a Route, the Current Route Page is displayed between the Map Page and the Trip Information Page (**the Current Route Page is only available during navigation**). The page shows a pointer which indicates the direction of travel from your current location to the destination, a list of the next three turns and the destination (turn direction arrow, turn description, distance and time for each).

To change the time displayed on the Current Route Page:

1. With the Current Route Page displayed, press **MENU**.
2. Select 'Show Times to Go' or 'Show Arrival Time'. Press **ENTER**.

It is often desirable to view the Next Turn Page from the Current Route Page.

To view the Next Turn Page from the Route List Page:

1. With the Route List Page displayed, press **ENTER**.
2. Press **ENTER** or **QUIT** when done looking at the next turn.
3. You can scroll through the entire list and highlight any of the turns in the list and view the next turn page for that turn.

To scroll through the list:

1. Use the **ROCKER KEYPAD** and scroll through the list stopping at the desired turn. Press **ENTER** and view the Next Turn Page for that turn. Press **ENTER** or **QUIT** to get back to the Route List Page.

Reference

Current Route Page

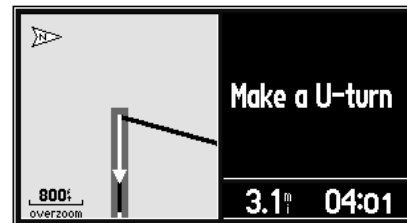

*The Next Turn Page can be viewed from the Current Route List Page by pressing the **ENTER** key.*

Reference

Trip Information Page



The Trip Information Page.



When using battery power, battery level is shown in the upper left corner of the Trip Information Page. When it turns red, it's time to replace the batteries.

Trip Information Page

The third main page is the Trip Information Page. If you are making a long trip, you will find the Trip Information Page very useful. It indicates your current speed and many helpful statistics about your trip. The following are useful suggestions to aid in maximizing the use of the Trip Information Page:

Be certain to reset the Trip Computer before beginning the trip. Instructions on resetting will follow. If you make frequent stops, leave the Navigator powered on and receiving satellites. This will allow the unit to accurately measure elapsed time during the trip. However, your vehicle may disconnect power to the Navigator when the ignition is turned off. In order to continue receiving satellites, use batteries as well. When external power is removed, the unit will then ask, with a screen prompt, if it can use the batteries when vehicle power is not available.

The following trip information is displayed on the Trip Information Page:

Driving Status Information - Displayed at the top of the page. Shows the next intersection (the crossroad name) or exit (if you are on an interstate) if one is approaching. Otherwise it tells you what road you are on.

Speed - This is the current vehicle speed.

Odometer - A running total of distance traveled, based upon the distance between second-by-second location readings, since the Trip Computer was last reset.

Current Direction - Displayed to the right of the speed.

Power/Battery - Displayed to the left of the odometer. When operating from external (vehicle) power, a power plug symbol is shown along with the label, External Power. If the Navigator is using internal AA batteries, a battery strength bar is shown (above the bar is a label, Battery Power). Notice the shaded area of the bar. The farther right the shading extends, the more battery power remaining. When operating on batteries, the bar and the label turn red when power is low (20% or less).

Driving Avg - Your average speed of travel during the time the vehicle has been in motion, since the Trip Computer was last reset.

Overall Avg - Your average speed of travel (including time stopped) during the time the Navigator has been tracking your location, since the Trip Computer was last reset.

Max Speed - The maximum speed recorded since the Trip Computer was last reset. Max Speed may also be reset individually, without resetting other Trip Computer information.

Driving Time - The length of time that the vehicle has been in motion, since the Trip Computer was last reset.

Stopped Time - The length of time that the vehicle has been stopped (stationary) during the time the Navigator has been tracking your location, since the Trip Computer was last reset.

Time - Shown to the right of the odometer

Total Time - The total length of time that the Navigator has been tracking your location, since the Trip Computer was last reset. This is always equal to Driving Time plus Stopped Time.

To reset the Trip Computer or the Maximum Speed:

1. Press the **MENU** key to display the Options window.
2. Use the **UP** and **DOWN** keys to select 'Reset Trip Computer'.
3. Press **ENTER**.
4. To reset the Maximum Speed only, select 'Reset Max Speed Only' and then press **ENTER**.

Reference

Trip Information Page



You can reset Max Speed or the Trip Computer from the Trip Information Menu.

Reference

Marking Waypoints



A waypoint is stored in memory as soon as the 'Waypoint Marked' Page appears.



There are approximately 50 waypoint symbols to choose from. These symbols are used to mark the waypoint's position on the Map Page.

Marking Your Location as a Waypoint

At times you may find it useful to mark a location, so that you can return to it again later. These locations are called 'Waypoints'. The Navigator can hold up to 500 Waypoints.

To mark your location as a Waypoint:

1. Press and hold **ENTER**. The 'Waypoint Marked' page appears, with a default three-digit name for the new waypoint in the upper-left portion of the page. The Navigator captures the location from the instant at which you pressed **ENTER**, so you do not need to be concerned about moving around or losing satellite reception, your Waypoint is safely stored.

To rename the Waypoint:

1. Use the **ROCKER KEYPAD** to select the name and press **ENTER**.
2. Enter the new waypoint name using the **ROCKER KEYPAD**, and press **ENTER**.

Each waypoint may also be assigned a custom waypoint symbol for easy recognition on the Map Page.

To change the Waypoint symbol:

1. Highlight the Waypoint symbol (immediately to the left of the waypoint name) and press **ENTER**. Use the **ROCKER KEYPAD** to select the desired symbol.
2. Press **ENTER** when you find the most appropriate symbol. The new Waypoint is now stored in memory.

At the bottom of the Waypoint Marked Page there are three selections that can be made:

Delete - deletes the waypoint.

Show Map - Shows the waypoint on the Map Page.

Route To It - Tells the unit that you want to navigate to that waypoint.

Using the Find Menu

You can search for Waypoints, Cities, BMW Dealers or Exits that are included in the Navigator basemap using the Find Menu. In addition, if you are using optional City Navigator map data, you can search for and find Points of Interest, Addresses, or Intersections. Your current location is normally used as the reference point for the 'Nearest', 'Distance', and 'Direction' features. However, if you are using the panning arrow (Map Pointer), it is used as the reference point.

Finding items 'by Name' or 'by Nearest'

Personal Waypoints, Cities, BMW Dealers and Points of Interest on the Find Menu can be viewed in two formats, 'By Name' (a list of every item available for a category) or 'By Nearest' (a list of only those items for a category that are nearby). The Find Nearest lists (nearest businesses, cities, waypoints, dealers and exits) update continuously. The yellow highlight can be introduced by pressing **ENTER** or any direction on the rocker keypad. Introducing the highlight allows you to scroll through and select any of the nearest items listed and it also freezes the list in its current order. To remove the highlight and resume continuous searching for nearest items, press the **QUIT** key.

To switch between 'By Name' and 'Nearest':

1. With a list of nearest items displayed, press the **MENU** key.
2. Highlight 'Find Nearest' or 'Find By Name' and press **ENTER**.

Finding an item by name:

1. The first character in the name field at the top of the page will be selected. Begin entering the name of the item you want, using the method for entering each letter or number described on page 11.
2. When you can see that the names of the items in the list below are near the name of the item you want, press **ENTER**.

Reference

Using the Find Menu

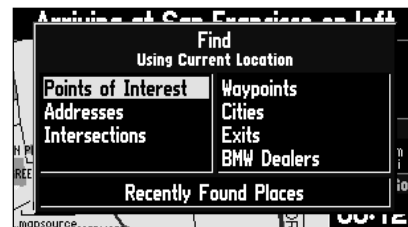

The Find Menu uses the built-in basemap, built-in dealer database and optional City Navigator CD Map Data.



You can find items by name or search for nearby items by category.

Reference

Using the Find Menu

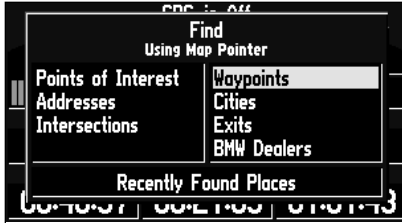

You can find waypoints, cities, interstate highway exits and BMW dealers without using the optional MapSource CD map data.



Nearest cities are listed in order according to their mileage from your present position.

3. Highlight the item you want from the list.
4. Press **ENTER** to display the information page for the item.

Finding a nearest item:

1. Highlight the item you want from the nearest list.
2. Press **ENTER** to display the information page for the item.

Finding a Waypoint

Waypoints that you have created and stored in the Navigator can be found by selecting the 'Waypoints' option of the Find Menu. You can find a waypoint from a list of waypoints 'By Name' or 'Nearest' using the procedure explained in the steps above.

The Waypoint Information Page (step 2 above) displays the waypoint name, a map symbol, the location in lat/lon, elevation and three on-screen buttons (Route to It, Show it on the Map, or Delete the waypoint).

Finding a City

Cities listed in the map database can be found by selecting the 'Cities' option of the Find Menu. The City Information Page for the selected city displays the city name, the size by population and the distance from your location. You can view it on the map ('Show Map') or 'Route to It' from your current location, or save the city location as a waypoint ('Save as Waypoint').

Finding a BMW Dealer

Your Navigator includes a built-in database of BMW dealers, which you may find helpful for locating parts, service or roadside assistance. Dealers can be found by selecting the 'BMW Dealers' option of the Find Menu. The Dealer Information Page for the selected BMW dealer displays the dealership name, address and phone number. You can view it on the map ('Show Map') or 'Route to It' from your current location, or save it as a waypoint ('Save as Waypoint').

Finding an Exit

You can use the Find Exit option to locate a nearby exit on an interstate highway. Exits are listed only by 'Nearest'. You can also search for exits on interstates other than the nearest one by choosing 'Select Exit Road' option from the list of exits.

To find an Exit:

1. Press the **FIND** key to display the Find Menu.
2. Use the **ROCKER KEYPAD** to select 'Exits' and then press **ENTER**. A menu will appear with a choice of exit types.
3. Highlight the type of exits you wish to view, then press **ENTER**.
4. A list of the nearest exits ahead of you will be displayed. The title of the list indicates the interstate which the exits are on. Direction and distance is shown on the right side of the list from your location to the selected exit.
5. Scroll through the list to select the desired exit.
6. Press **ENTER** to display the Exit Page for that exit. This page contains the exit description at the top of the page and a list of services near that exit at the bottom. You can show the exit on the map or save it as a waypoint.
7. Use the **ROCKER KEYPAD** to highlight an item from the list of services, then press **ENTER**.
8. A page will appear, showing the type of services, its direction from the exit and a list of services available, each marked by a check.

Reference

Using the Find Menu



Nearest Services		
① BMW of San Francisco	NE	1.6 ^m
① Schleicher Motors	E	15.2 ^m
① Diablo Kawasaki/BMW	NE	23.4 ^m
① California BMW	SE	30.4 ^m
① San Jose BMW	SE	41.4 ^m
① Santa Rosa Suzuki-BMW	N	48.8 ^m

MENU to find by name

Nearest dealers are listed in order according to their mileage from your present position. Highlight a listed dealer and press **ENTER** to display more information.

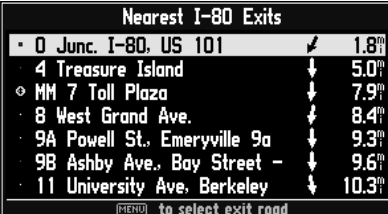

Nearest I-80 Exits		
• 0 Junc. I-80, US 101	↗	1.8 ^m
4 Treasure Island	↓	5.0 ^m
◦ MM 7 Toll Plaza	↓	7.9 ^m
8 West Grand Ave.	↘	8.4 ^m
9A Powell St., Emeryville 9a	↓	9.3 ^m
9B Ashby Ave., Bay Street	↓	9.6 ^m
11 University Ave., Berkeley	↘	10.3 ^m

MENU to select exit road

Once you locate the item of your choice, press **ENTER** to display an information page for that item. To view all of the exits in the list, use the scroll bar on the right side of the display.

Reference

Using the Find Menu



Scroll through the Points of Interest list to see all of the Points of Interest that are available, including Emergency and Government.

Finding a Point of Interest

You must be using MapSource MetroGuide or City Navigator which provides this type of map data, otherwise this option is unavailable.

To locate a point of interest:

1. Press the **FIND** key to display the Find Feature Menu. Select 'Points of Interest' and press **ENTER** to display a list of categories.
2. Select the category of your choice and then press **ENTER** to display the list of types.
3. Select the type of your choice and press **ENTER** to display a list of the points of interest first for that type.
4. Follow instructions on page 27 to find a point of interest by name or nearest.
5. Select the desired point of interest on the list and press **ENTER** to display the information page. The information page will include the full name, type, address, and phone number. You can choose to save the selection as a waypoint, show it on the map, or route to it. Select your choice and press **ENTER**.

When searching for points of interest using the 'By Name' list, multiple items with the same name appear only once on the list (e.g., "McDonalds"). When you select it and press **ENTER**, a list of 'Nearest' for that name will appear.

Finding an Address or an Intersection

You must be using MapSource MetroGuide or City Navigator which provides this type of map data, otherwise these options are not selectable.

To locate an address:

1. Press the **FIND** key to display the Find Feature Menu. Select the 'Address' option and then press **ENTER** to display the 'Find Address' page.
2. Select the Number field and use the method for entering numbers as explained on page 11.
3. Move to the 'Street' field using the **ROCKER** keypad.
4. Press **ENTER** to display the 'Select Street Name' list. Find the street you want following the instructions for finding an item by name on page 27 of this manual.
5. With the desired street selected, press **ENTER** to place the street name on the find page.
6. Select the 'Find' button and press **ENTER** to view the 'Select Address' page with a list of possible address matches. A window at the bottom of the list displays the quality of each address match.
7. Select an address and press **ENTER** to display the 'Address' page, from which you can view the address on the map or 'Route to It'.
8. If there are multiple matches, use the optional city and postal code fields to place the best matches near the top of the list.

To locate an intersection:

The 'Find Intersection' feature operates like the Find Address feature, with the exception that you enter first and second street names instead of an address and a street name.

Reference

Using the Find Menu

Find Intersection	
First Street	Zachary Dr
Second Street	Hwy 2
City (optional)	Appleton City, MO
Postal Code (optional)	64012
Find	

You must be using the optional MapSource data or finding an address is not possible.

Reference

Using the Find Menu



The most recently reviewed item is at the top of the recently found list and they are listed in reverse chronological order.

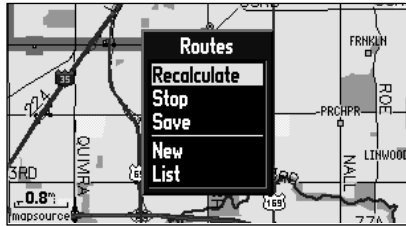

The 'Routes' Menu can be accessed from any page by pressing the **ROUTE** key.

Recently Found Places

Each recent list will hold fifteen items. The last fifteen businesses are listed in the 'POI' list, the last fifteen cities are in the 'Cities' list, etc. The most recently reviewed item is at the top of each list and the list is in reverse-chronological order. You can use the Recently Found Places option to locate Points of Interest, Addresses & Intersections, Cities, and Other locations. The Recently Found Places page is denoted by a 'file tab' at the top that identifies the function of that page.

To locate a Recently Found Place:

1. Press the **FIND** key to display the Find Feature Menu. Select 'Recently Found Places' and press **ENTER** to display a list of places (you can also display the recently found places page by pressing and holding down the **FIND** key). Select the file tab category of your choice to display the list.
2. Select the desired item on the list and press **ENTER** to display the information page. The information page will include the full name, type, address, and phone number (only for points of interest). You can choose to save the selection as a waypoint ('Save as Waypoint'), show it on the map ('Show Map'), or 'Route to It'. Select your choice and press **ENTER**.

Using the Routes Menu

The Routes Menu gives you five options to manage the Navigator Routes feature. The five options are:

Recalculate (or Cancel) - Recalculates the active route for faster time or shorter distance. If the Navigator is currently calculating a route, Cancel is displayed, allowing you to cancel the route calculation in progress.

Stop or Resume - Stops the route being navigated (or the simulated route). Or resumes a currently stopped route.

Save - Saves the active route.

New - Starts an entirely new route.

List - Selects a Route to start from a list of saved routes.

To Start a New Route:

1. Press the **ROUTE** key to view the Routes Menu. Select 'New' and press **ENTER**. The Find Destination window appears.
2. Follow the instructions given on page 27 to select a Find Destination item. Once the Information Page is displayed for the item you found, select 'Route to It' and press **ENTER**.
3. The Route Preference Window appears (unless disabled by the 'Ask Me My Preference' setting).
4. From the Route Preference window select 'Faster Time', 'Shorter Distance', or 'Off Road' (or 'Don't Ask Again'). See page 43 for a description of these four options.
5. Press **ENTER**. The Thumbnail Route Map appears in the lower left-hand corner of the Map Page. The unit is now ready to navigate the new route.

To Select a Route to start from a List of Saved Routes:

1. Press the **ROUTE** key to view the Routes Menu. Select List and press **ENTER**. The Select a Route to Start window appears.
2. Use the **ROCKER KEYPAD** to select a saved route from the list. Press **ENTER**. The unit is now ready to navigate the route.

To Recalculate a Route:

1. Press the **ROUTE** key to view the Routes Menu. Select 'Recalculate' and press **ENTER**.
2. The Route Preference Window appears (unless disabled). From the Route Preference window select Faster Time, Shorter Distance, or Off Road (or Don't Ask Again). See page 43 for a description of these four options.
3. Press **ENTER**. The Thumbnail Route Map appears in the lower left-hand corner of the Map Page. The unit is now ready to navigate the route.

To Stop a Route:

1. Press the **ROUTE** key to view the Routes Menu.
2. Select Stop and press **ENTER**. The current route becomes inactive.

Reference

Using the Routes Menu



If you want a faster time instead of a shorter distance, you can recalculate the route at any time.

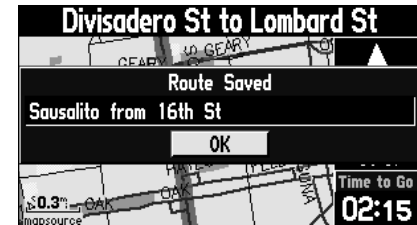

To save a route, select 'Save' from the Routes menu and press the 'OK' button on the Route Saved window.

Reference

Using the Routes Menu

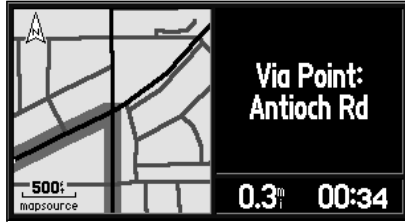

To create a route for the Navigator with multiple points or destinations, you must use MapSource City Navigator. With City Navigator, you can create an auto-route with any combination of waypoints, cities, intersections and points of interest and download the route to the Navigator.

Any intermediate point in an auto-route calculated in City Navigator is called a 'via' point in the Navigator. Refer to the MapSource Owner's Manual for instructions on creating routes.

To Save a Route:

1. Press the **ROUTE** key to view the Routes Menu. Select 'Save' and press **ENTER**. The Route Saved window appears, showing the active route.
2. Press **ENTER** ('OK button') to confirm the name and save the route (the name can be edited here). There can be up to 50 saved routes.

Deleting and Renaming Routes

You can delete all of the routes that exist in the unit or you can delete a single route. You can also rename a route.

To Delete all Routes:

1. Press the **ROUTE** key to view the Routes Menu. Select 'List' and press **ENTER**. The Route List appears with all routes. Press the **MENU** key ('delete all' is selected). Select 'Yes' in the verification window and press **ENTER**.

To Delete a single Route:

1. Press the **ROUTE** key to view the Routes Menu. Select 'List' and press **ENTER**. The Route List appears with all routes. Select the single route to delete and press the **MENU** key. Select 'Delete' and press **ENTER**. Select 'Yes' in the verification window and press **ENTER**.

To Rename a Route:

1. Press the **ROUTE** key to view the Routes Menu. Select 'List' and press **ENTER**. The Route List appears with all routes. Select the single route to rename and press the **MENU** key. Select 'Rename' and press **ENTER**. Use the Rocker Keypad and enter the new route name.

GPS Information Page

The GPS Information Page provides a visual reference of GPS receiver functions, including current satellite coverage, receiver status, and position accuracy. As the Navigator locks onto satellites, a signal strength bar will appear for each satellite in view, with the appropriate satellite number (from 01-32) underneath each bar. The progress of satellite acquisition is shown in three stages:

- No Signal Strength Bar- the receiver is looking for the satellite(s) indicated. The corresponding number(s) on the sky view is not highlighted.
- Hollow Signal Strength Bar- the receiver has found the satellite and is collecting data.
- Solid Signal Strength Bar- the receiver has collected the necessary data and the satellite(s) is ready for use. The corresponding number(s) on the sky view is highlighted.

Each satellite has a 30-second data transmission that must be collected (hollow signal strength bar, as described above) before that satellite may be used for navigation (solid signal strength bar). Once a fix has been calculated, the Navigator will then update your position, ground track, and ground speed by selecting and using the best satellites in view.

Sky View and Signal Strength Bars

The sky view and signal strength bars give you an indication of what satellites are currently visible, which satellites are being used to calculate a position fix, and the signal quality. The sky view shows a "bird's eye" view of each satellite's position relative to the unit's last known position. The outer circle represents the horizon in all directions (with cardinal heading references). The inner circle represents an elevation of 45° above the horizon. Any satellite depicted near the center is directly overhead. You can use the sky view to help determine if any satellites are being blocked, and whether you have a current position fix (indicated by '2D Navigation' or '3D Navigation' in the status field). You can also set the sky view to a 'Track Up' configuration (instead of 'North Up'), causing the top of the sky view to align to your current track heading.

Reference

GPS Information Page

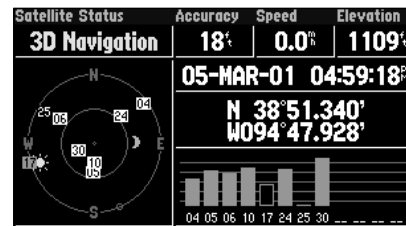

A hollow bar (number 17) indicates the receiver has found the satellite and is collecting data.

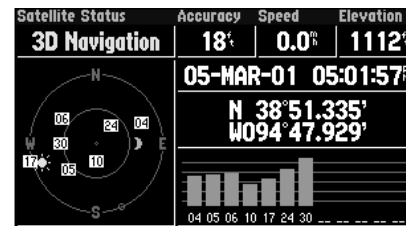

Solid bars indicate the receiver has collected the necessary information and the satellite is ready for use.

'Poor Satellite Reception' Menu

If no satellites are received for several minutes (or an insufficient number of satellites are received to determine a position fix) a message will appear, prompting you to update your approximate location or turn off the GPS for indoor use. Updating your approximate location will ensure the Navigator is searching for the correct satellites, and is useful if you have traveled over 500 miles with the unit turned off. If the unit has been stored without batteries and the displayed date is incorrect, the Navigator will not know the current positions of the GPS satellites. Selecting 'Stored w/o Batteries' will tell the unit to search for any satellites that it can find.

The 'Poor Satellite Reception' prompt may appear when you first use your Navigator. The prompt may also appear during normal use if the antenna is shaded or when the unit is used indoors.

Accuracy

The GPS Information Page indicates the accuracy of the position fix. See Appendix E for the Navigator performance specifications which include accuracy.

Reference

GPS Information Page



The 'Poor Satellite Reception' Menu gives you several options when an insufficient number of satellites are received to determine a position fix.

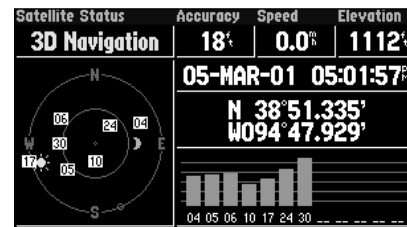

The sun and moon icons on the satellite skyview are for reference (notice that the icons are grayed if the sun/moon is below the horizon). You can see the sunrise and sunset times for your current location and date on the Time Setup Page.

Reference

GPS Information Page

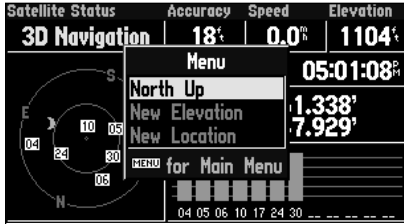

Selecting 'North Up' will display the sky view with North at the top.

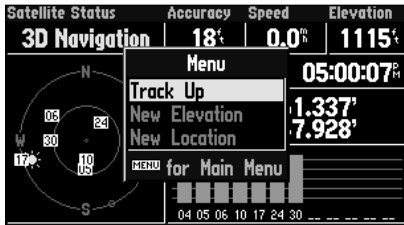

Selecting 'Track Up' will automatically rotate the sky view to keep your current direction of travel at the top of the display.

GPS Information Page Options

To display the GPS Information Page Options, press **MENU** (with the GPS Information Page displayed). The following Options are available:

- Track Up (or North Up)
- New Elevation
- New Location

Track Up- changes the sky view display from 'North Up' orientation to align to current direction of travel (ground track). If 'Track Up' is selected, 'North Up' will appear as an option instead.

To change the sky view orientation:

1. Use the **ROCKER KEYPAD** to highlight 'Track Up' (or 'North Up') and press **ENTER**.

New Location- forces the Navigator to search for any available satellite to determine its position. This option is useful if you've relocated a long distance (greater than 500 miles) from the last location the Navigator was used. In such instances, without initialization, the Navigator may otherwise be looking for the wrong group of satellites.

To select New Location, highlight 'New Location' and press ENTER.

New Elevation- allows you to designate your approximate elevation, when the Navigator is acquiring satellites or navigating with a two-dimensional position. By default, 2D navigation will attempt to use the last known elevation. If the elevation shown is off by several hundred feet (or more), manually entering your approximate elevation will enable the receiver to more accurately determine a position fix.

To enter an elevation:

1. Use the **ROCKER KEYPAD** to Highlight 'New Elevation' and press **ENTER**.
2. Enter your approximate elevation using the **ROCKER KEYPAD**, and press **ENTER**.

MapSource Info

The MapSource info option displays version and map name(s) for any MapSource CD-ROM data stored on an installed cartridge. A box appears to the immediate left of each map name (directly under 'Enabled'). When the box is checked, the designated MapSource data will appear on the map—at the appropriate map scales and when within the boundaries of that map's area.

Also, when the box is checked the automatic routing data for that area is available. Routing data is prioritized by type. If City Navigator and MetroGuide data are both available for the same area, the City Navigator data will be used to determine routing. Keep this in mind, since there may be times (e.g., outside the urban core area of City Navigator's data) when using MetroGuide data will be preferable.

To turn individual MapSource maps on or off:

1. Optional MapSource data must first be uploaded to a cartridge installed in your Navigator.
2. Select the 'MapSource Info' option from the Main Menu, then use the **ROCKER KEYPAD** to scroll through the list of available maps.
3. If a check mark appears in the box to the left of a map name, that map is turned on and will appear on the map display. If necessary, highlight the name of any listed map and press **ENTER** to add or remove the check mark.

Address and POI (points of interest) Find functions are always enabled for any MapSource City Navigator or MetroGuide map loaded on the cartridge, regardless of whether the 'Enabled' box is checked or not.

System Info

The System Info window shows the unit software version and unit ID number which you need to have handy when you are unlocking detailed coverage areas from the GARMIN web site (see the Quick Start Guide for details).

Reference

Map Source/System Information

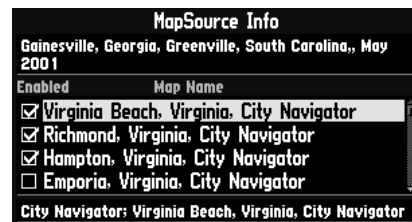

Check the box for the MapSource data that you want displayed on the map.



You will need the unit ID number to unlock detailed coverage areas from the GARMIN web site.

Reference

System Setup



The System Setup Pages allows you to customize the features of the Navigator.



You can completely reset the system setup features to their original settings.

System Setup Pages

The System Setup Pages can be accessed by pressing the **MENU** key twice from any page to display the Main Menu. Select 'System Setup' and press **ENTER**. This group of pages is used to perform various System Setup functions. Each selectable page is denoted by a 'file tab' at the top that identifies the function of that page.

To select a System Setup option:

1. With the System Setup on the screen, select the file tab for the desired function. The associated information and options are automatically displayed when the file tab is selected.
2. Once the desired file tab has been selected use the **ROCKER KEYPAD** to select the desired option to view or modify.
3. Press **ENTER** to change to a different option. In most cases, a list of available options is shown.
4. Use the **ROCKER KEYPAD** to select the desired choice, then press **ENTER** again to accept the change.
5. Use the **UP** key to return to the file tab area and select another file tab, if desired.

At some time, you may desire to change part of the System Setup back to the way it was the first time you used your Navigator. This can be done by selecting the option called 'Restore Original Settings'.

To restore the original settings:

1. Use the **ROCKER** keypad to move the cursor to the file tab for which you want to restore the original settings.
2. Press the **MENU** key. A window is displayed with 'Restore Original Settings' selected.
3. Press **ENTER**. Only the settings for that file tab are modified.
4. If desired, repeat steps 1 through 3 for other file tabs.

The file tab headings and System Setup functions are:

General - GPS Mode, Keypress Tones, Attention Tone, Voice, Battery Type, and Units.

Guidance - Off-Route Recalculation, and Next Turn Pop-Up.

Routing - Route Preference, Calculation Method, Ask Me My Preference, Calculate Routes for, and Avoid (U-Turns, Toll Roads, and Highways).

Time - Time Format, Daylight Savings, Time Zone, Time, Date, Sunrise, and Sunset

Safety - 'Safe Mode' On and Off.

Track Log - Recording, Percentage Full, and Clear Track.

Language - Selects desired operating language for on-screen Text and for audio Voice prompts.

Interface - Selects the proper interface format.

The following pages describe, in more detail, the available setting for each System Setup file tab item.

General File Tab

GPS Mode - Allows you to choose between three operating modes, 'Normal' with the GPS receiver operating, 'Battery Saver' with a less frequent satellite signal updating process to save on battery power, and 'GPS Off' which allows you to operate the Navigator indoors (which saves on even more battery power since the unit is not "listening" to satellites). The 'Use Indoors' option on the Map Page options menu sets the operating mode to 'GPS Off'.

Keypress Tones - Allows you to determine whether or not the internal beeper sounds; On or Off. The beep confirms that a button has been pressed.

Attention Tones - Determines if the voice prompts are preceded by a chime.

Reference

System Setup

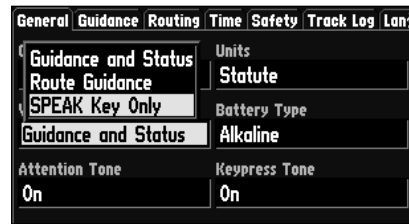

You can select when you want Voice Prompts to occur.

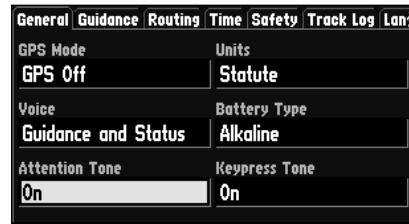

The 'Attention Tone' field determines if voice prompts are preceded by a chime.

Reference

System Setup



The 'Off Road' option is useful if you stop somewhere on your trip where there are no roads (scenic area, etc.) and you want to still navigate (via a straight line) using the Navigator.

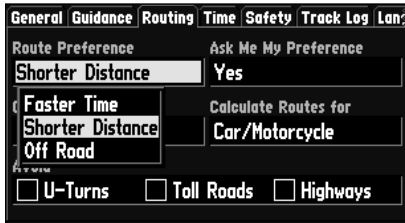

Remember that a route with 'Shorter Distance' selected will be shorter in distance but may take more time to ride!

Voice - The setting determines when the voice (and chime, if enabled) sounds. Selecting 'Guidance and Status' allows the voice to be heard during navigation (e.g., "Drive point eight miles west and turn right"). The single tone chime comes before all automatic voice navigation messages (if enabled). There are three possible voice messages per route leg. The first one comes right after you have completed a turn and are starting a new leg. The voice message will be preceded by a lower pitched tone. The second message will come somewhere toward the end of the leg depending on how fast you are going. This message is also preceded by this lower pitched tone. The last message on the route leg comes right before a turn and is preceded by a higher pitched tone.

Battery Type - Used to designate the type of batteries currently being used to power the Navigator; Alkaline or Ni-Cad (Nickel Cadmium).

Units - Allows you to select the desired units of measure for distance in Miles or Kilometers. If you select Miles, the speed will be shown in Miles per Hour and the elevation will be shown in feet.

'Guidance' File Tab

Off-Route Re-calculation - Controls how the Navigator recalculates the route when you depart from the route.

Next Turn Pop-Up - Controls when the Next Turn Page is displayed.

Routing File Tab

The Routing Tab allows you to customize the routing features of the Navigator.

Route Preference—Determines what criteria are used for finding the route to your destination. The following options are available:

- **Faster Time:** This setting causes time to be used as the criteria for calculating your route. The routes calculated with this setting will result in a faster ride but may be longer in distance.
- **Shorter Distance:** This setting causes distance to be used as the criteria for calculating your route. The routes calculated with this setting will be shorter in distance but it may be a longer (time) ride.
- **Off Road:** This setting causes your route to be a direct line from you to your destination. This may be useful outside of detailed map coverage areas.

Calculation Method—Allows you to control how thoroughly the Navigator searches for the perfect route. There is a trade-off between the length of time it takes to find a route and the quality of that route (or how close to the ideal route as determined by your Route Preference setting). The following options are available:

- **Quickest Calculation:** This will give you the fastest results, minimizing the time you have to wait.
- **Best Route:** This will cause route calculations to take somewhat longer, but you will get the best possible route.

Reference

System Setup

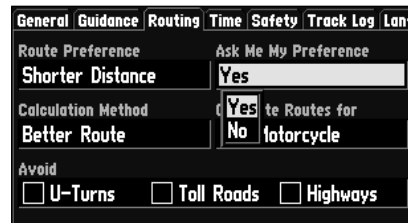

The 'Ask Me My Preference' setting can also be changed from the Routing File Tab. This allows you to determine your preference each time you select a new route.

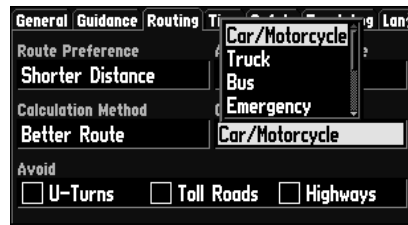

Using the 'Calculate Routes For' option allows you to take full advantage of the routing information contained in the City Navigator Maps for planning the most efficient route for your type of vehicle.

Reference

System Setup

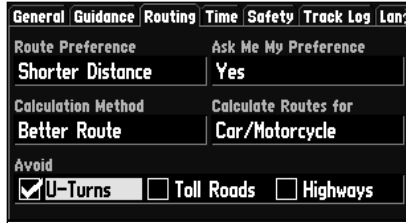

U-Turns can be avoided when planning your route.



Routes can be calculated for emergency-type vehicles, to take advantage of all possible routing options (including otherwise prohibited U-turns).

Ask Me My Preference—Determines whether or not you will be prompted before route calculations to allow you to change your current Route Preference (Faster, Shorter, or Off Road). This setting can also be changed from 'Yes' to 'No' from the Route Preference page. The following options are available:

- Yes: This setting results in the Route Preference page being displayed before route calculations. If you frequently have a different preference for your routes, this is the setting you want.
- No: This setting skips the Route Preference page before route calculations. The Navigator will use your current Route Preference for all route calculations. If you usually have the same preference for your routes, this is the setting you want.

Calculate Routes For—Lets you take full advantage of the routing information built into the City Navigator maps. Some roads have vehicle-based restrictions associated with them. For example, a street or gate may be accessible by emergency vehicles only. Or a residential street may not allow commercial trucking traffic. By specifying what vehicle type you are riding or driving, you can avoid getting routed somewhere that you cannot legally go. Likewise, it may give you access to roads or turns that wouldn't be available to normal traffic. The following options are available:

- Car/Motorcycle: Self-explanatory.
 - Truck: Large semi-tractor/trailer.
 - Bus: Self-Explanatory.
 - Emergency: Ambulance, Fire, Police, etc.
 - Taxi: Self-Explanatory.
 - Delivery: Delivery Vehicles
 - Bicycle: This will restrict you from taking interstates and major highways.
 - Pedestrian: Self-Explanatory.
-

Avoid - Lets you avoid certain things that may be undesirable in your route.

U-Turns: If checked, the Navigator will not tell you to make a U-turn unless absolutely necessary.

Toll roads: If checked, the Navigator will avoid entering toll roads, but still use these roads if the alternatives take you too far out of your way.

Highways: If checked, the Navigator will avoid interstates and major highways, but will still use these roads if the alternatives take you too far out of your way.

Time File Tab

Time Format - Allows you to choose from a 12 or 24 hour time format. When you select the 12 hour time format, the clock will read like a standard clock with 12 hour AM and PM cycles. The 24 hour option sets the clock to display a 24 hour cycle (Military Time).

Time Zone - Can be set to one of the U.S. Time Zones, or by selecting 'Other' you can enter the UTC Time Offset for any other time zone. Refer to the instructions for setting UTC Time Offset and the Time Offset Chart on page 55.

Daylight Savings Time - Can be turned On or Off or set to Automatic.

Current **Date** and current **Time** are determined by the satellites being received and can not be changed. Sunrise and Sunset times are calculated for your present position.

Reference

System Setup

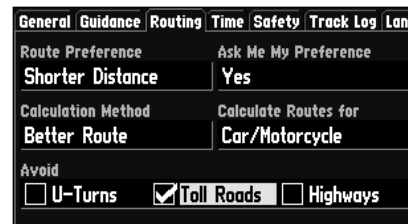

Toll Roads can be avoided when planning your route. However, the Navigator will still use Toll Roads if a suitable alternate route does not exist.

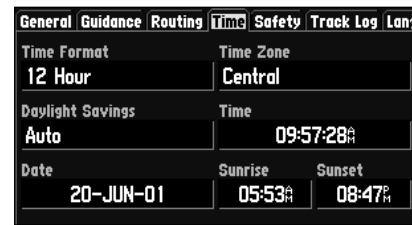

Remember that current date and time are determined by the satellites and cannot be changed.

Reference

System Setup

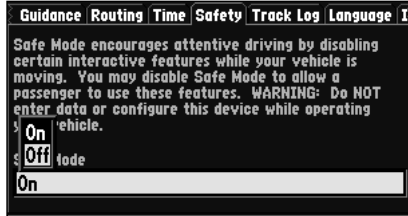

The 'Safe Mode' can be turned off to allow a passenger to operate the unit.

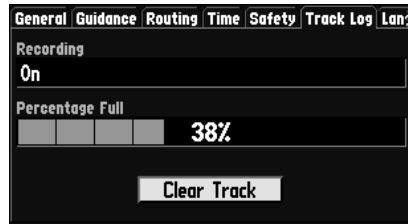

Select the 'Clear Track' Button on the Track Log Page to clear all of the stored tracks.

Safety Tab

Your Navigator is equipped with a Safe Mode feature to improve rider safety. By default, this feature is enabled. For automotive use, Safe Mode can be turned off to allow a passenger to operate the unit. When your vehicle is moving, Safe Mode disables Navigator functions which require significant operator attention and may become a distraction to use while riding. Disabled functions include:

- Map Panning
- All **FIND** key functions (except Recent List)
- All **MENU** key functions
- Creating new routes

When you come to a complete stop, these features are automatically re-enabled.

Track Log Tab

The Navigator automatically records a history of your locations in the 'Track Log', creating an electronic 'bread crumb' trail of the path you have traveled. Once full, new track points will replace the oldest track points. The beginning of the track is the earliest point while the end is the most recent. The display of the track log on the map can be turned on and off in the Map Setup (the default is 'Off').

Recording - Select 'On' or 'Off'; 'On' to record tracks, 'Off' stops tracks from being recorded.

Percentage Full - Shows the percentage of track memory used.

Clear Track - Clears the track log from memory.

Language Tab

The Navigator's Language Setup feature allows you to change the languages used for on-screen text and for voice prompting.

Text Language- This changes all on-screen text on all pages and menus to the selected language. Changing the Text Language setting does not affect the display of map data or user-entered data. Map data such as city, street, and point of interest names will always be displayed in the language in which they are stored in the map.

Voice Language- This changes the language used for all voice commands and messages. To change the Voice Language, you must have a second voice installed. Voice data for foreign languages are found on-line at <http://www.garmin.com/products/spIII>.

Reference

System Setup

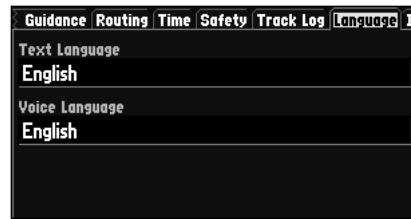

Only English is pre-installed when you purchase the Navigator.

Reference

System Setup



The Interface Tab provides for eight possible Input and Output settings (including 'None').

Interface Tab

The 'Interface' file tab provides the following input/output settings:

- GARMIN—the proprietary format used to exchange waypoint, route, track log data with a PC. The format used for database updates and to save MapSource CD-ROM data to an installed data cartridge.
- GARMIN DGPS—the proprietary format used to receive differential corrections from a GARMIN DGPS Beacon Receiver and automatically scan/tune beacon frequencies.
- NMEA—supports the input/output of standard NMEA 0183 version 2.30 data.
- Text Out—supports a standardized, fixed-column ASCII output with data for position, track, speed, etc.
- RTCM In—allows Differential GPS (DGPS) input using a standard RTCM SC-104 format, without any output capabilities.
- RTCM In/NMEA Out—allows DGPS input using a standard RTCM format and also provides NMEA 0183 version 2.30 output.
- RTCM In/Text Out—allows DGPS input using a standard RTCM format and also provides a standardized, fixed-column ASCII output with data for position, track, speed, etc.
- None—provides no interfacing capabilities.

To select an input/output interface format:

1. With the System Setup on the screen, select the file tab for 'Interface' and press **ENTER**.
2. Use down portion of the **ROCKER KEYPAD** to select the 'FORMAT' field and press **ENTER**.
A pop-up window will show the available settings.
3. Use the **ROCKER KEYPAD** to select the desired setting and press **ENTER**.
4. If required for the setting, highlight the 'BAUD RATE' field, press **ENTER**, select the desired rate and press **ENTER** again.
5. For GARMIN DGPS and RTCM In/NMEA Out, the 'BEACON' field may be set to 'Scan' or 'Manual'.
If 'Manual' is selected, enter the beacon frequency and bit rate in the appropriate fields.

Reference

System Setup



You can select an I/O Interface Format from the Format Menu.

Appendix A

Optional Accessories



The GA26C Low Profile Remote Antenna



Non-Skid Friction Mount



128 MB Data Card

Optional Accessories



WARNING: *Garmin accessories have been designed and specifically tested for use with Garmin products. Accessories offered for sale by other manufacturers have not been tested or approved for use with Garmin products. Use of such accessories could cause damage to the Navigator and void the warranty.*

In addition to the standard accessories included with the Navigator (page 2 in the Quick Start Guide), the following optional accessories are designed to enhance the operation of the Navigator:

Contact GARMIN Customer Service at (913)-397-8200 or 1-800-800-1020, or your GARMIN Dealer to obtain Replacement Parts and Optional Accessories.

- **GA 26C Low Profile Remote Antenna**

Magnetic or suction mounts with 8 ft. cable and BNC connector.

- **Non-Skid Friction Mount**

No installation required. For use in your car or other vehicle.

- **128 MB Data Cards**

Max out the memory in your Navigator with this data card. Holds up to 128 megabytes of data from MapSource CD-ROMs so you can download street-level map detail, points of interest, business addresses and phone numbers, topographic information and more. Replacement 64 MB data cards are also available.

- **Handheld/Portable Antenna**

For use in your car or other vehicle. Attaches directly to the back of your Navigator.

- **Single DCA Unlock Code Certificate**

Provides additional coverage for the U.S. and Canada.

- **Carrying Case**

With storage for data cartridges.

- **AC Adapter**

Allows you to operate the Navigator using standard AC household power.

Appendix A

Optional Accessories



The Handheld/Portable Antenna



Single DCA Unlock Code Certificate



Carrying Case

Appendix B

Wiring and Interfacing

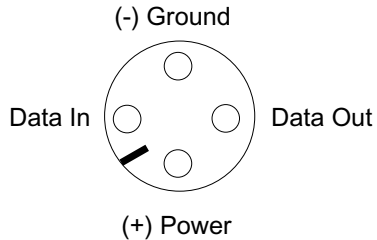

Power and Data Connections from the back of the unit.

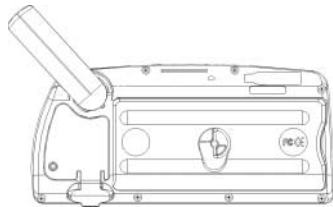

To attach the optional portable antenna: rotate to the position shown in the picture above and gently push onto the unit. The antenna port accepts a standard BNC connector.

The Navigator can be connected to a PC, beacon receiver, marine autopilot or other compatible device using the supplied PC Interface Cable with RS-232 Serial Port Connector (P/N 010-10141-00).

The Navigator can be connected to a vehicle's electrical system and a PC, beacon receiver, marine autopilot, or other compatible device using the optional PC Interface Cable with Cigarette Lighter Adapter (P/N 010-10165-00).

The Navigator may be hard-wired to the vehicle's electrical system (10-32 VDC) and a PC, beacon receiver, marine autopilot or other compatible device using the Power/Data Cable with bare wire leads (P/N 010-10082-00).



WARNING: *the terms of the GARMIN Warranty require that the Power/Data Cable with bare wire leads be installed by experienced installers at a qualified installation facility (i.e., your BMW dealership). The user should not attempt installation without proper knowledge of motorcycle/automotive electrical systems and skill in the use of special tools or hardware required for installation.*

Consult the wiring diagrams at the side and bottom of the page for proper connections. (The male connector on the back of the Navigator and wiring leads are illustrated to the right, wiring lead color coding is illustrated below.)

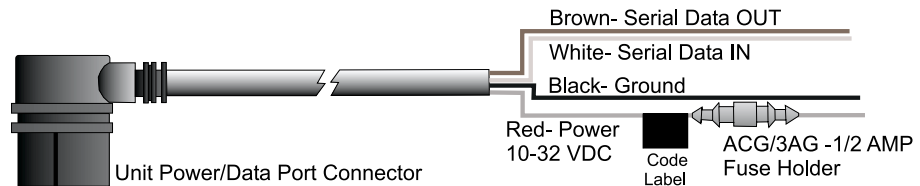

Cleaning

The Navigator is constructed of high quality materials and does not require user maintenance other than cleaning. Clean the unit using a cloth dampened with a mild detergent solution and then wipe dry. Avoid chemical cleaners and solvents that may damage plastic components.

Storage

Storing alkaline batteries in the unit for extended periods is not recommended. In order to reduce the chance for battery leakage in the battery compartment and map data card slot, remove the batteries when storing the unit for more than six months.

Water Immersion

The Navigator is waterproof to IEC Standard 529 IPX7. It can withstand immersion in 1 meter of water for 30 minutes. Prolonged submersion can cause damage to the unit. After submersion, be certain to remove the batteries and map cartridge and dry the compartments before reuse.

To resolve problems that cannot be remedied using this guide, Contact GARMIN Customer Service at 913-397-8200.

Appendix D

Messages

The Navigator uses an on-screen message system to alert you to unit operating characteristics. Press the **ENTER** key to acknowledge and return to the page you were viewing.

Using City or Postal Code May Help - More addresses or intersections were found than can be displayed. If the specific address or intersection you are looking for is not in the list, try entering a city or postal code and searching again.

Antenna Shorted To Ground - Check antenna wiring or antenna placement.

Battery Voltage Low - The batteries are low and should be replaced.

Basemap Failed - The unit's basemap has failed. Return the unit to GARMIN for service.

Can't Unlock Maps - At least one map on the data card is locked.

Data Transfer Complete - Transfer of data to the unit from PC software has been completed.

Database Error - A waypoint or route failed to store in memory. If the problem persists, return the unit to GARMIN for service.

GPS Turned Off for Indoor Use - GPS satellite reception has been disabled for indoor use.

Lost Satellite Reception - The unit has lost satellite signals. Check antenna connections or try moving it to a location with a clear view of the sky.

Memory is Full - The unit's memory is full. To reduce the amount of memory used, delete unused routes, waypoints, or track log data.

Memory (RAM) Failed - The unit has detected a failure in its internal memory. If this message persists, the unit is unusable - return it to GARMIN for service.

Memory (ROM) Failed - The unit has detected a failure in its permanent memory. If this message persists, the unit is unusable - return it to GARMIN for service.

No Diff GPS Position - No differential correction data is available or not enough data is available to compute a DGPS position.

None Found - A search through MapSource data, using the selected criteria, has produced no matching results.

Processor Failed - The unit has detected a fault in its internal processor. If this message persists, the unit is unusable - return it to GARMIN for service.

Route Memory is Full - Route memory is full and no more routes can be saved or added (from another GPS unit or a PC).

Route Truncated - The route has been truncated because it was too long. There will be turns missing prior to the destination.

Route Waypoint Memory is Full - There is no more space for map-based route waypoints (used for turns).

Safe Mode is Turned On - The action attempted is disabled while moving to prevent distractions while riding.

Sunrise, Switching to Day Mode - The map is switching to the Day Mode display.

Sunset, Switching to Night Mode - The map is switching to the Night Mode display.

That Route Name is Already Used - The route name you have entered is already being used by another route.

Too Many Maps on Data Card - The data card contains more maps than the unit software can process.

Too Many Vias for Road Navigation - The route contains too many via points (intermediate destinations). The route can only be navigated in an off-road, or point-to-point fashion.

Track Memory is Full - Track Log memory is full. No additional track log data can be stored without deleting old data to create memory space.

Track Truncated - A complete uploaded track will not fit in memory. The oldest track log points were deleted to make space for the most recent data.

Waypoint Memory is Full - You have used all 500 waypoints available. Delete unwanted waypoints to make space for new entries.

Waypoint Name Already Used - The waypoint name you have entered is already used by another waypoint.

Appendix E

Specifications

PHYSICAL

Case:	Rugged; fully gasketed
Size:	3.2"H x 6.8"W x 2.6"D (8.0 x 17.3 x 6.5 cm)
Weight:	1.4 pounds (635 g)
Display:	3.4"W x 1.8"H (8.6 x 4.5 cm), (305 x 160 pixels), high-contrast, 16-color backlit LCD
Antenna:	Detachable with standard BNC-type connector
Temp. Range:	5° to 158°F (-15° to 70°C) ¹

PERFORMANCE

Receiver:	Differential-ready 12 parallel channel
Acquisition Time:	Warm: Approximately 15 seconds
	Cold: Approximately 45 seconds
	AutoLocate™: Approximately 2 minutes
Update Rate:	Once per second, continuous
GPS Accuracy	
Position:	<15 meters (49 feet), 95% typical ³
Velocity:	0.05 meter/sec steady state

DGPS Accuracy

Position:	3-5 meters (10-16 feet), 95% typical
Velocity:	0.05 meter/sec steady state
Dynamics:	Performs to specifications to 6 g's
Interfaces:	NMEA 0183, RTCM (for DGPS corrections) and RS-232 for PC interface
Data Storage Life:	Indefinite; no memory battery required
Map Storage:	Data Cards store detailed map data

POWER

Source:	Six 1.5-volt AA batteries or 12 V Adapter Cable
Battery Life:	2-20 hours based on backlight setting ⁴

Specifications subject to change without notice.

1. The temperature rating for the Navigator may exceed the usable range of some batteries. Alkaline batteries can rupture at high temperatures.
2. With optional GARMIN GBR 21/23 Beacon Receiver Input.
3. Subject to accuracy degradation to 100m 2DRMS under the U.S. DOD-imposed Selective Availability (SA) Program.
4. Alkaline batteries lose a significant amount of their capacity as temperature decreases. Use Lithium batteries when operating the Navigator in below-freezing conditions. Extensive use of bright screen backlighting will significantly reduce battery life. Low to moderate screen backlighting can significantly prolong battery life.

Appendix F

Installing the Batteries

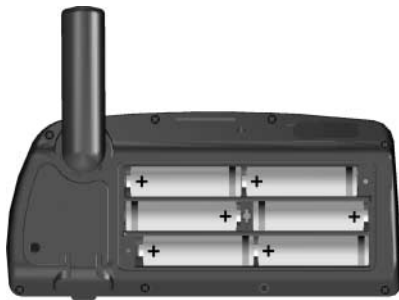

- Observe correct polarity when installing batteries.
- Replace all batteries at the same time.
- Do NOT mix new and used batteries.
- Do NOT mix Alkaline batteries with Lithium or Ni-Cad rechargeable batteries.

Immediately after you install new batteries, turn the unit on to ensure that the unit's battery strength indicator displays a fully-charged battery condition.

If the unit does not turn on or the battery level indicator displays a partially charged battery condition, recheck for proper battery installation. If, after checking installation, the battery level indicator continues to indicate a partially charged condition, the newly installed batteries may be depleted from long-term storage. Replace with fresh batteries.

The Navigator uses six (6) AA batteries, which are installed at the back of the unit. Alkaline, rechargeable, Lithium, or Ni-Cad batteries can be used. Battery life will vary due to a variety of factors, including surrounding temperature and the use of backlighting. You may find that Lithium batteries provide longer life in colder conditions. Saved information will not be lost when you replace the batteries.



WARNING: It is very important to install ALL batteries with the proper polarity, positive (+) or negative (-), orientation as indicated in the unit's battery compartment. Batteries can leak and cause personal injury and property damage if you install them incorrectly.

A power symbol (electrical plug) appears at the bottom of the Main Menu and in the upper left hand corner of the Trip Information Page (see page 24) when the unit is running on external power. When the unit is running on AA batteries, instead of the power symbol a green battery strength bar indicator appears. The bar shortens as the unit uses battery power. To conserve battery life you can switch to Battery Saver mode (see Owner's Manual page 41) or you can use the vehicle power.

When the battery power falls below a certain level, the bar indicator turns red. You should replace the batteries when this occurs. In addition, a 'battery voltage is low' message appears at the bottom of the page.

To install the batteries:

1. Lift up the metal D-ring at the back of the unit and turn it ¼ turn counterclockwise to open the compartment door.
2. Install the batteries (as shown at left and as marked in the battery compartment).
3. Turn the D-ring ¼ turn clockwise to lock the door in place.

This chart is provided to help you determine the standard time offset settings for your current location in order to set the correct time on the Time Setup Page. To change the UTC (Universal Time Coordinate) Offset, if necessary, press the **MENU** key twice to access the Options Menu. Then scroll down to the System Setup option, press ENTER to access and then tab over to the 'Time' page. Highlight the UTC Offset field and press **ENTER** to enter the appropriate offset value from the chart below using the **UP** or **DOWN** areas of the **ROCKER** keypad. To determine your longitudinal zone, press **MARK** to show the Longitude on the Waypoint Marked Page. It should fall between one of the sets of values on the chart.

Longitudinal Zone	Offset	Longitudinal Zone	Offset
W180.0° to W172.5°	-12.00	E007.5° to E022.5°	+01.00
W172.5° to W157.5°	-11.00	E022.5° to E037.5°	+02.00
W157.5° to W142.5°	-10.00	E052.5° to E067.5°	+03.00
W142.5° to W127.5°	-09.00	E067.5° to E082.5°	+04.00
W127.5° to W112.5°	-08.00	E082.5° to E097.5°	+05.00
W112.5° to W097.5°	-07.00	E097.5° to E112.5°	+06.00
W097.5° to W082.5°	-06.00	E112.5° to E122.5°	+07.00
W082.5° to W067.5°	-05.00	E122.5° to E127.5°	+08.00
W067.5° to W052.5°	-04.00	E127.5° to E142.5°	+09.00
W052.5° to W037.5°	-03.00	E142.5° to E157.5°	+10.00
W037.5° to W022.5°	-02.00	E157.5° to E172.5°	+11.00
W022.5° to W007.5°	-01.00	E172.5° to E180.5°	+12.00
W007.5° to E007.5°	-00.00		

Appendix H

Index

A

Accessories (optional).....	48
Addresses.....	27
Antenna.....	9
Arrival Time.....	22
Arrow, Panning.....	16
AutoLocate.....	36
Auto-Routing.....	1
AutoZoom.....	20

B

Battery.....	35-36
Battery Installation.....	58
Beeper.....	41
BMW dealers.....	29

C

Cities.....	20, 27-28
Clearing the Track Log.....	46
Configuring the Map.....	18

D

Data Entry.....	2, 10-11
Date/Time.....	45
Directions, Vehicle.....	13-15
Driving, Instructions.....	14-21
DGPS Interface Settings.....	46

E

External Power.....	24, 42
Exits.....	27-29

F

Features.....	11, 17
File Tabs.....	19, 40
Find.....	27-31
Full Screen Map.....	13

G

GPS Info Page.....	35
--------------------	----

H

How To Enter Data.....	11
------------------------	----

I

ID Number.....	39
Initialization.....	36, 38
Installation.....	7, 49
Interfacing.....	50
Intersections.....	10, 27, 32, 51

K

Keypad Usage.....	10
-------------------	----

L

Language Feature	47
Local Time Offset	56

M

Main Pages	12
Map Page.....	13
MapSource Info Page.....	39
Messages	52

N

Navigation.....	10-12, 17-18
Nearest.....	27-30
Night Mode.....	52
NMEA Output Formats.....	46-47
North-Up.....	20, 35, 38

O

Odometers, Trip.....	24-25
Overzoom	15

P

PAGE Key.....	10
Points of Interest	30
Power On/Off.....	10
Power/Backlight/Contrast Key.....	10

Q

QUIT Key.....	10
---------------	----

R

Restore Settings.....	40-41
Routes.....	32-34, 41-44

S

Safe Mode	46
Satellite Sky View (Location).....	35
Signal Strength Bars.....	35
Software Version.....	39
Specifications	54
System Setup.....	40

T

Time Format	45
Time Offsets.....	56
Time Zone.....	45
Trip Computer	24-25

U

U-Turns.....	41, 45
--------------	--------

W

Warnings.....	4
Warranty	8
Waypoint Lists	26-28, 51-52
Wiring Installation	50

Z

Zoom In/Out.....	13-15
------------------	-------



© 2001 GARMIN Corporation

GARMIN International, Inc.

1200 East 151st Street, Olathe, Kansas 66062, U.S.A.

GARMIN (Europe) Ltd.

Unit 5, The Quadrangle, Abbey Park Industrial Estate, Romsey, SO51 9AQ, U.K.

GARMIN Corporation

No. 68, Jangshu 2nd Road, Shijr, Taipei County, Taiwan

www.garmin.com

Part Number 190-00206-10 Rev. B